



The Best For Over 85 Years!

OVERFILL PROTECTION

2" NPT OVERFILL VALVE

Application -

All new 2" overfill valve. The new 47-20 fits 2" tank openings. With no minimum flow rate this valve can be used for a wide variety of applications.

Part Number - 47-20



UNIVERSAL Advantage

Only Universal Valve offers a 2" overfill valve designed to operate with no minimum flow rate. Making this valve the most versatile overfill on the market.

Features -

- ✓ No minimum flow rate to operate
- ✓ No line shock, gradual shut-off
- ✓ No float hang up
- ✓ Prevents overfills in tanks reducing contamination and costly clean-up
- ✓ Completely automatic operations
- ✓ Easily retrofitted to existing tanks
- ✓ 2" NPT tank opening
- ✓ 55gpm at 30PSI
- ✓ 10PSI = 100gpm
- ✓ Max 100PSI
- ✓ Max 150 Centistokes

Construction -

- Hard coated aluminum
- Reinforced closed cell float
- Buna gaskets

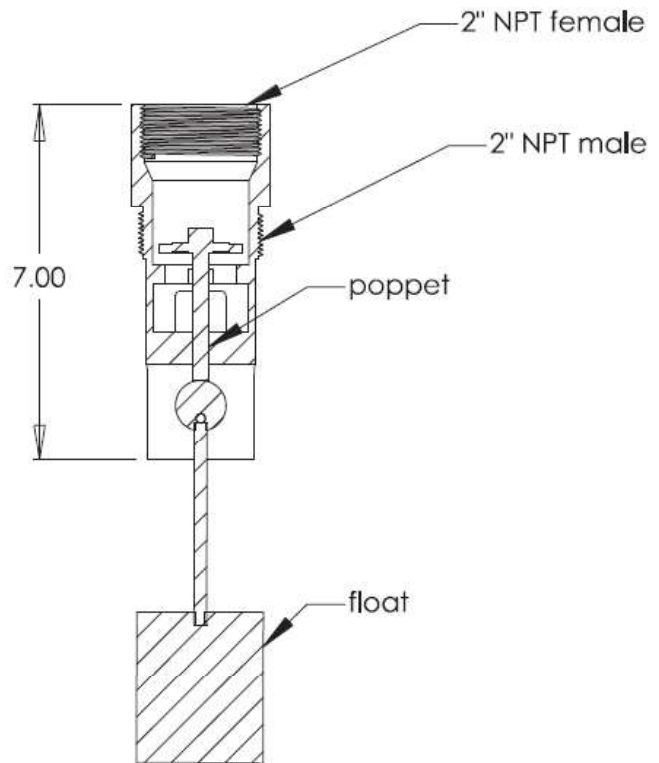

Model# Weight (lbs.)

47-20 1.86

Replacement Parts

Part Numbers	Description
47-F	Float
47-G	Float Rod

Notice: Universal Valve Co., products must be used in compliance with applicable federal, state, and local laws and regulations. Product selection should be based on physical specifications and limitations and compatibility with the environment and material to be handled. Universal Valve Co., makes no warranty of fitness for a particular use. All illustrations and specifications in this literature are based on the latest production information available at the time of publication. Prices, materials, and specification are subject to change at any time, and models may be discontinued at any time, in either case, without notice or obligation.

UNIVERSAL VALVE COMPANY

478 Schiller Street, Elizabeth, NJ 07206 • (800) 223-0741 • (908) 351-0606 • Fax: (908) 351-0369 • universalvalve.com

© 2020 Universal Valve Company, Inc.