



Family Owned Over 75 Years. We Care!



AST PRODUCTS

SWING CHECK VALVES

Application -

Designed to prevent back flow in a horizontal pipe.

Part Number - 246



Features -

- ✓ Metal to metal seal
- ✓ Heavy wall brass body construction
- ✓ 300 lb. WOG
- ✓ Threaded ends
- ✓ Available in pressure relief
- ✓ Available with Teflon Seals

Construction -

- All brass body
- Brass hanger pin and plug

Model	Description	Weight (lbs.)	A	B
246-15 1-1/2"	Swing Check Valve	1.98	3.63	2.42
246-20 2"	Swing Check Valve	2.82	4.26	2.72
246-30 3"	Swing Check Valve	7.75	5.87	3.75
246-40 4"	Swing Check Valve	12.75	7.125	4.5
246PR-15 1-1/2"	Swing Check Valve Pressure Relief	1.98	3.63	2.42
246PR-20 2"	Swing Check Valve Pressure Relief	2.82	4.26	2.72
246PR-30 3"	Swing Check Valve Pressure Relief	7.75	5.87	3.75
246PR-40 4"	Swing Check Valve Pressure Relief	12.75	7.125	4.5

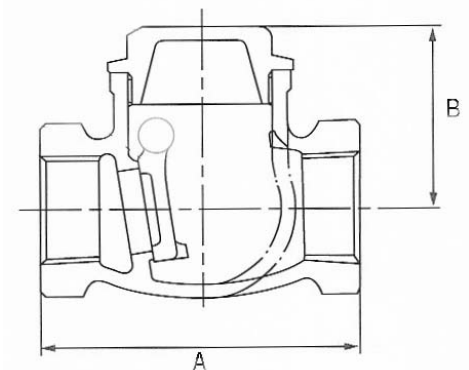

Notice: Universal Valve Co., products must be used in compliance with applicable federal, state, and local laws and regulations. Product selection should be based on physical specifications and limitations and compatibility with the environment and material to be handled. Universal Valve Co., makes no warranty of fitness for a particular use. All illustrations and specifications in this literature are based on the latest production information available at the time of publication. Prices, materials, and specification are subject to change at any time, and models may be discontinued at any time, in either case, without notice or obligation.

UNIVERSAL VALVE COMPANY

478 Schiller Street, Elizabeth, NJ 07206 • (800) 223-0741 • (908) 351-0606 • Fax: (908) 351-0369 • universalvalve.com

© 2009 Universal Valve Company, Inc.