



Family Owned Over 75 Years. We Care!

# MULTI-PURPOSE CHECK VALVES

## PRESSURE RELIEF NIPPLE CHECK VALVES

### Application -

Universal 212BPR and 212VPR are mounted in fuel lines at the submersible pump to hold the prime and prevent premature tripping of mechanical leak detectors. The valves relieve thermal expansion between the pump head and dispenser.

### Part Numbers - 212BPR, 212VPR



### Features -

- ✓ For suction systems
- ✓ Heavy wall bronze body construction eliminates seat distortion
- ✓ Available with Buna-N or Viton seals
- ✓ Pressure relief valve set at 0-14, 15-35, or 36-50 psi
- ✓ Large selection of sizes
- ✓ Pressure relief valve relieves thermal expansion in line between pumping unit and dispenser
- ✓ U.L. Approved

### Construction -

- Bronze body
- Buna-N or Viton seals

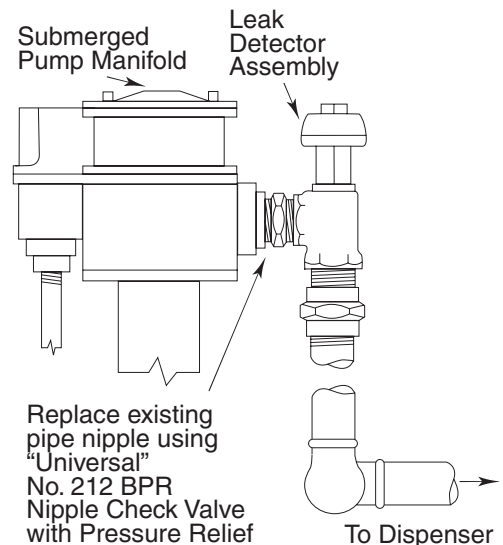

Model	Size	Weight (lbs.)	Height	Width	Seal
212BPR-15-014	1-1/2"	1.2	3-1/8"	2-1/2"	Buna-N
212BPR-15-1535	1-1/2"	1.2	3-1/8"	2-1/2"	Buna-N
212BPR-15-3650	1-1/2"	1.2	3-1/8"	2-1/2"	Buna-N
212VPR-15-014	1-1/2"	1.2	3-1/8"	2-1/2"	Viton
212VPR-15-1535	1-1/2"	1.2	3-1/8"	2-1/2"	Viton
212VPR-15-3650	1-1/2"	1.2	3-1/8"	2-1/2"	Viton
212BPR-20-014	2"	1.8	3-3/16"	2-5/8"	Buna-N
212BPR-20-1535	2"	1.8	3-3/16"	2-5/8"	Buna-N
212BPR-20-3650	2"	1.8	3-3/16"	2-5/8"	Buna-N
212VPR-20-014	2"	1.8	3-3/16"	2-5/8"	Viton
212VPR-20-1535	2"	1.8	3-3/16"	2-5/8"	Viton
212VPR-20-3650	2"	1.8	3-3/16"	2-5/8"	Viton

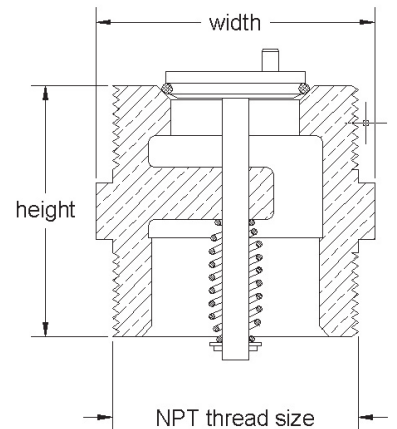

Notice: Universal Valve Co., products must be used in compliance with applicable federal, state, and local laws and regulations. Product selection should be based on physical specifications and limitations and compatibility with the environment and material to be handled. Universal Valve Co., makes no warranty of fitness for a particular use. All illustrations and specifications in this literature are based on the latest production information available at the time of publication. Prices, materials, and specification are subject to change at any time, and models may be discontinued at any time, in either case, without notice or obligation.

### UNIVERSAL VALVE COMPANY

478 Schiller Street, Elizabeth, NJ 07206 • (800) 223-0741 • (908) 351-0606 • Fax: (908) 351-0369 • universalvalve.com

© 2012 Universal Valve Company, Inc.